

Hot jacket remover

JR-6

Guide to operation





IMPORTANT SAFETY PRECAUTIONS

This product has been designed and manufactured to assure personal safety. Improper use can result in bodily injury and serious damage to the jacket remover. Please read and observe all warnings instructions given in this operation manual.



◆ The meaning of these symbols

In the product and this operation manual, symbols are used to highlight warnings and cautions for you to read so that accidents can be prevented. The meanings of these symbols are as follows:

<The meaning of these symbols>

	This symbol indicates a caution, danger, or warning and alerts you important instructions have been included on the product or in the manual.
	This symbol indicates actions that are prohibited.
	This symbol indicates actions that must be taken.

<The meaning of Warning and Caution>

 Warning	This symbol indicates explanations about extremely dangerous matters. If users ignore this symbol and handle the jacket remover the wrong way, serious injury such as fire or electric shock, or death could result.
 Caution	This symbol indicates explanations about dangerous matters. If users ignore this symbol and handle the jacket remover the wrong way, bodily injury and damage to the equipment could result.

Be sure to read all the following warnings and cautions before use.



<Using jacket remover>

	<ol style="list-style-type: none"> 1. This product meets IPX1 (water proof protection Class 1) defined by JIS C0920. However do not intentionally expose the jacket remover to water or touch it with wet hands. Failure to do so may cause fire, electric shock or malfunction. 2. If water gets into the jacket remover, turn off the power and remove the battery or unplug the AC adapter. Next, contact our maintenance service center.
---	--



3. If an abnormal condition such as smoke, unusual odor, unusual noise, or heat generation occurs, immediately turn off the power. Next, contact our maintenance service center.
4. Do not touch the heat plate during use. The heat plate and its peripheral parts are very hot. Doing so may cause burn.
5. Do not disassemble or modify this product. Doing so may cause fire, electric shock or malfunction.

<Handling of battery>



1. Do not disassemble or modify the battery. Safety and protective devices to prevent danger are built in the battery. If these devices are damaged, excessive current flow may cause heat generation, smoke, bursting and fire.
2. Do not directly connect the positive and negative terminals with a conductive material such as a wire.
Do not carry or store the battery together with any personal jewelry, hairpins or other metallic objects. Doing so can cause an electrical short circuit. Also excessive current flow may cause heat generation, smoke, bursting and fire.
3. Do not throw it into a fire or burn the battery. Heat will melt insulates, damage safety devices and cause chemical reaction in battery fluid, resulting in heat generation, smoke, bursting and fire.
4. Do not use or leave the battery under high temperature conditions such as near fire or stove. Doing so may cause heat generation, smoke bursting and fire.
5. Do not let water or sea water wet or soak the battery. Protective devices are built in the battery. If these devices are damaged, excessive current flow may cause, heat generation, smoke, bursting and fire.
6. Do not charge the battery close to heat sources or under the blazing sun. Protective devices to prevent danger are built in the battery. If these devices are damaged, excessive current flow may cause chemical reaction in battery fluid, resulting in heat generation, smoke, bursting and fire.
7. Only use a specified battery charger. Failure to do so can cause the battery to be overcharged or excessive current flow may cause abnormal chemical reaction in battery fluid, heat generation



- smoke, bursting and fire.
8. Do not pierce the battery with a needle, strike the battery with a hammer, or step on the battery. Doing so may cause internal short circuit, resulting in heat generation, bursting and fire.
 9. Do not throw or impact the battery. Protective devices are built in the battery. If these devices are damaged, excessive current flow may cause abnormal chemical reaction in battery fluid, resulting in heat generation, bursting and fire.
 10. Do not solder any lead wires directly to the battery. Heat will melt insulates and damage protective devices, resulting in heat generation, smoke, bursting and fire.
 11. Do not place the battery in microwave ovens, high-pressure containers. Doing so may cause heat generation, smoke, bursting and fire.
 12. Use the battery only for the application for which it was designed. Failure to do so will result in a loss of performance and shortened battery life expectancy. Also excessive current flow may cause damage to the jacket remover, heat generation, bursting and fire.
 13. Do not use or leave the battery under high temperature such as in strong direct sunlight and cars during hot weather. Failure to do so will result in a loss of performance and shortened battery life expectancy.



14. Make sure polarities are correctly connected. Do not attempt to connect the battery module when you cannot do. Reversed connections may cause abnormal chemical reaction in battery fluid, resulting in heat generation, bursting and fire.
15. In the event the battery leaks and the fluid gets into one's eyes, do not rub the eyes. Immediately wash them thoroughly with clean water enough from the tap and consult a doctor urgently. Failure to do so could result in serious damage to the eyes.
16. Do not charge a fully charged battery. Doing so may cause the battery to be heated up, resulting in shortened battery life expectancy.
17. When disposing of the battery, follow the local regulations or contact our maintenance service center.



<Handling of AC adapter and power cord >



1. Only use a supplied DC cord (part number: PC-B[C]) when performing DC operation with a fusion splicer. Failure to do so may cause the jacket remover to operate poorly and malfunction.
2. If you are not going to use the jacket remover for a long period, unplug the AC adapter to reduce the risk of fire.
3. Unplug the AC adapter by grasping the plug, not the cord. Failure to do so may cause damage to the AC cord.

<Storage >



1. Avoid places with too much moisture, dust and dirt. Failure to do so may cause fire, electric shock or malfunction.

<Using jacket remover / Maintenance >



1. For your safety do not remove glass fiber fragments with bare hands after removal. Use a supplied cleaning brush and clean the blade peripheral parts with it.
2. Prepared fiber and glass fiber fragments are extremely sharp. Handle with care.
3. Blades are consumables. Only use Sumitomo genuine blades for replacement. Always replace both blades at a time. Install the blades in place. Failure to do so may cause the jacket remover to be damaged or deteriorated in performance.

<Handling of battery>



1. Do not remove the battery with wet hands. Failure to do so may cause fire, electric shock or malfunction.
2. The battery's optimum charging temperature range is 0 to 40°C. Avoid charging the battery at extremely low temperature (below 0 °C). Failure to do so may result in shortened battery life expectancy and battery leakage.
3. If you are not going to use the battery for a long period, remove it from the jacket remover. Failure to do so will shorten battery life expectancy as very little current flows while the jacket remover with a battery is powered off.

1. General

Thank you very much for purchasing the JR-6 hot jacket remover.

The JR-6 features the industry's first hot jacket remover that meets IPX1 (water proof protection Class 1) defined by JIS C0920 and achieves splash-proof and excellent removing performance with compact and lightweight body.

Before using the JR-6, read this manual carefully in its entirety to fully understand product capabilities. Save this manual in a location in which you can easily get to see.

The JR-6 is designed for splash-proof performance and meets IPX1 (water proof protection Class 1; vertically falling drops shall have no harmful effect) defined by JIS C0920.

However please note that it does not provide any guarantees that accident and damage will not arise.



Splash-proof design

2. Product overview

Specification

Optical fiber requirement	
Optical fiber material	Silica glass
Coating material	UV cure resin
Fiber count	Single fiber: Fiber coating 0.25~ 0.4mm 2 to 12-fiber ribbons: Coating thickness 0.3~0.4mm
Cladding diameter	125µm

Specification	
Coating removal length	Max. 30mm
HEATER MODE	NORMAL MODE
	POWER SAVE MODE
Temperature setting	4 positions: Approx. 80°C~140°C
Fiber holding method	FHS or FHM series fiber holders are used.

Power source	1) Battery operation: with BU-6 battery 2) AC operation: AC 90~264V, 50/60Hz with ADC-1220S AC adapter 3) DC 12V supplied from Sumitomo fusion splicer with PC-B[C] DC cord
Dimensions	45(W) x 138(D) x 38(H) mm
Weight	Approx. 155g (without battery)
Environmental conditions	Operating temperature: 0°C~+40°C Storage temperature: JR-6: -40°C~+60°C BU-6: -20°C~+40°C (if stored for less than 3 months) -20°C~+20°C (if stored for less than 1 year) Humidity: 0%~95% (non-condensing)
Others	Battery level check: Battery remaining capacity is indicated in one of four levels when the JR-6 is powered on.

Standard package / Options

<Standard package>

Description	Part number	Q'ty
Hot jacket remover	JR-6	1pc
Battery	BU-6	1pc
AC adapter	ADC-1220S	1pc
AC cord for AC adapter	-	1pc
Operation manual	OME0926019	1pc
Carrying case	SSB-02	1pc
Strap	-	1pc
DC cord	PC-B[C]	1pc
Cleaning brush	-	1pc
Hex driver (US) or Allen key (UK)	-	1pc

<Options>

Description	Part number	Q'ty	Remark
Replacement blades	JR-6BL	1 pair	Upper blade and lower blade
Single fiber adapter	SFA-6	1pc	For removal of single fiber coating

3. Structure

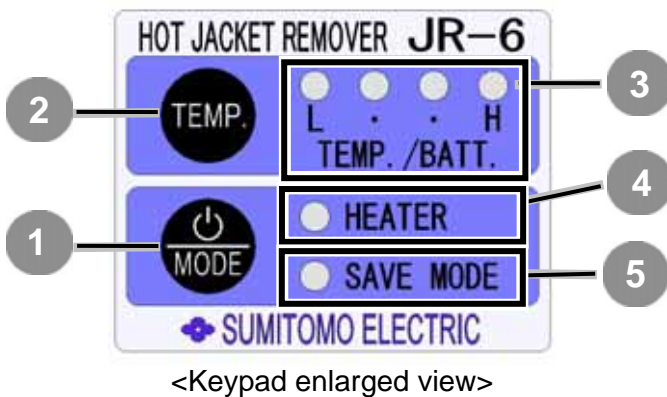
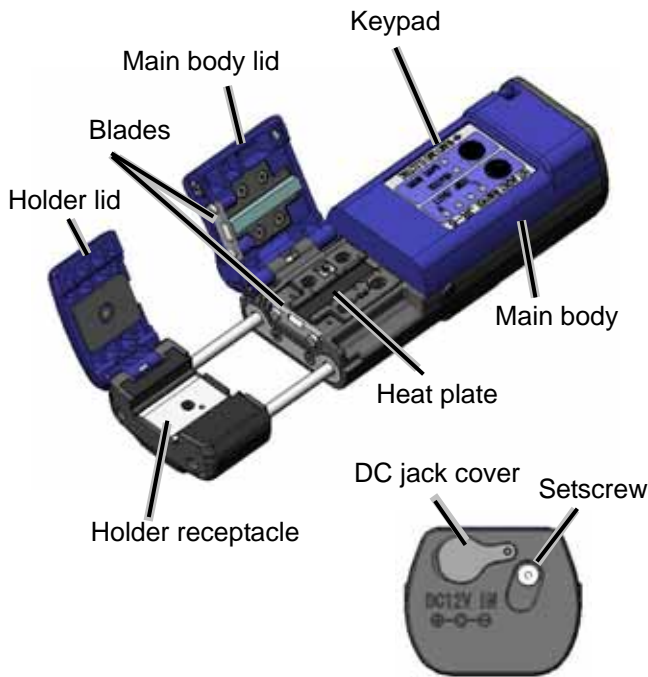

- 1 **POWER / HEATER MODE key**
Used to turn on and off the JR-6 and switch between NORMAL MODE and POWER SAVE MODE while the power is on.
- 2 **Heat plate temperature switching key**
Used to change the set temperature of the heat plate.
- 3 **TEMP./BATT. (Temperature / Battery level) indicator LEDs**
Illuminate to indicate set temperature / current battery remaining capacity.
- 4 **HEATER LED**
Illuminates while the heat plate is heated up.
- 5 **SAVE MODE LED**
Illuminates while the JR-6 is operated in POWER SAVE MODE.

4. Preparing power supply

There are 3 power supply methods for JR-6 operation.

1. Battery operation
2. AC operation
3. DC12V supplied from Sumitomo fusion splicer

Battery operation

The BU-6 battery is a rechargeable Lithium-Ion battery. You can recharge the battery before you have fully discharged it. The BU-6 is not charged fully at the factory. Charge it before use.

The BU-6 is installed in the JR-6 upon delivery.

Battery level check

Turn on the JR-6 by pressing the POWER key (1) for more than 1 second. Right after the JR-6 is powered on, TEMP./BATT. indicator LEDs (3) light up to give an instant indication of a current battery remaining capacity in one of four levels.

LED Status	Battery remaining capacity ratio (%)
●●●●	More than 75%
●●●○	50% ~ 75%
●●○○	25% ~ 50%
●○○○	Below 25%

If a battery remaining capacity ratio is below 10% during operation, the leftmost LED flashes in red to warn the battery will be dead soon.



The leftmost LED flashes in red.

Charging the battery

The BU-6 can be charged while installed in the JR-6.

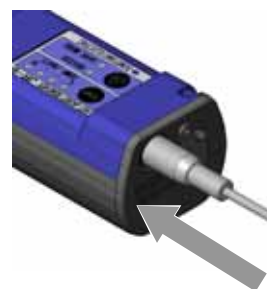

1. Install the BU-6 in the JR-6. (Refer to "Battery replacement".)
2. Connect the ADC-1220S AC adapter to the DC jack of the JR-6 and plug it.

3. Once charge is started, the leftmost LED of TEMP./BATT. indicator LEDs (3) flashes in green.



The leftmost LED flashes in green.

4. Charging time is different depending on the remaining capacity. Typically charge is complete in approximately 2 hours. The leftmost LED of TEMP./BATT. indicator LEDs (3) lights up green.

LED status	Battery status
Lit	Charge is complete.
Flashing	The BU-6 is being charged.
Off	The BU-6 or JR-6 is faulty. (Contact our maintenance service center.)

 **Warning**
Charge the battery within a temperature range of 0°C to 40°C. Failure to do so will shorten battery life and may cause battery leakage, heat generation, bursting and fire.

 **Caution**
Only use the JR-6 and the ADC-1220S AC adapter (or Sumitomo fusion splicer) to charge the battery. Failure to do may cause electric shock or fire.

Battery replacement

1. Unscrew the setscrew with a supplied Hex driver (US) or Allen key (UK). Remove the battery cover.

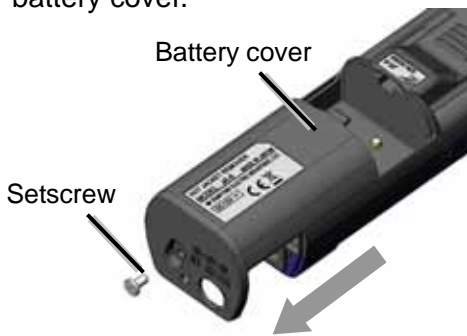

2. Slide a new battery into the JR-6.

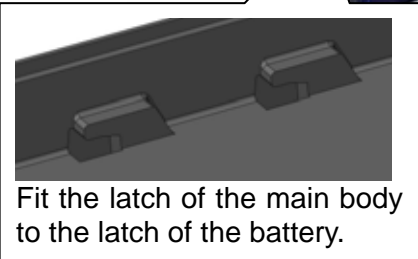
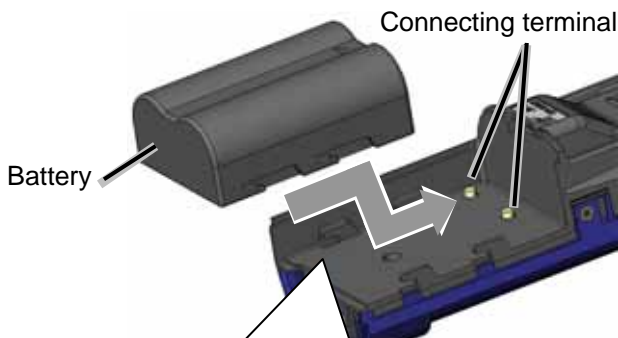



3. Refit the battery cover. Tighten the setscrew with a Hex driver (US) or Allen key (UK).



 **Caution**
Install the battery with a correct polarity.



 **Caution**
Be sure to close the cover completely. A gap between parts will not bring out satisfactory splash-proof performance.



AC operation



Connect the ADC-1220S AC adapter to the DC jack of the JR-6 and plug it.

 **Tips**
When the ADC-1220S AC adapter is connected to the JR-6 in which the battery is installed and the JR-6 is powered on, AC operation is prioritized. (Battery operation is not available.) Battery charge is started if the JR-6 is powered off.

DC12V supplied from Sumitomo fusion splicer



1. Connect a supplied DC cord (part number: PC-B[C]) to the DC jack of the JR-6.
2. Connect the DC cord to the DC output terminal of a fusion splicer.

3. While the fusion splicer is powered on, DC12V can be supplied to the JR-6. Battery charge is started if the JR-6 is powered off.

*With use of Sumitomo TYPE-39 or TYPE-66 fusion splicer, DC power can be supplied from the fusion splicer in which battery or AC operation is selected.

*With use of Sumitomo TYPE-25e fusion splicer, DC power can ONLY be supplied from the fusion splicer in which AC operation is selected.

If you would like to use the JR-6 with fusion splicers other than TYPE-39/TYPE-66/TYPE-25e, contact our maintenance service center.

5. Operating procedures



1. Press the POWER key (1) for more than 1 second until the TEMP./BATT. indicator LEDs (3) illuminate.

The indicator LEDs illuminate to indicate a current battery remaining capacity. Then the HEATER LED (4) flashes in red. The HEATER LED turns green when the JR-6 reaches the set temperature.

2. Place an optical fiber in a fiber holder with the ends protruding approx. 30mm.

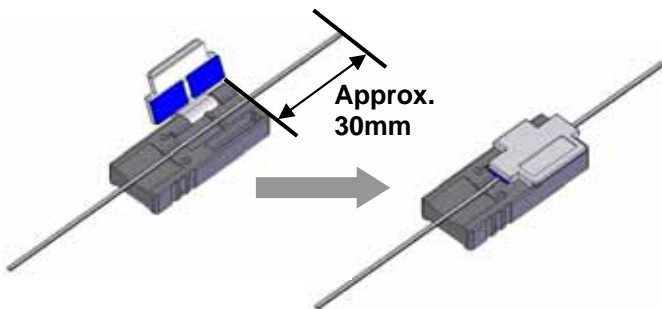

3. Place the fiber holder in the holder receptacle.



Removal area

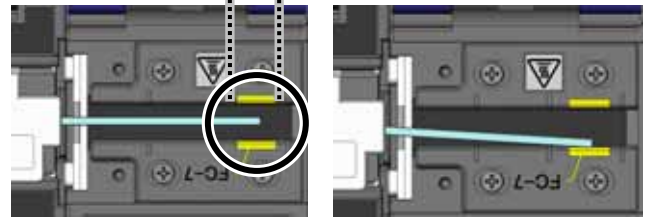

Good

No good

Tips

With use of Sumitomo fiber cleavers, ensure that the coating end is positioned in a specified area indicating "FC-7".

4. Close the main body lid and holder lid. The HEATER LED (4) flashes in green for approx. 5 seconds, and then keeps illuminated.

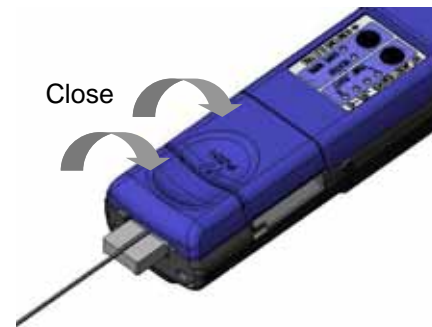

The HEATER LED flashes in green for approx. 5 seconds.



The HEATER LED lights up green.

5. Ensure that the HEATER LED (4) is lit in green and hold the JR-6, especially the "PUSH" portion of the main body lid firmly. Then slide the holder receptacle and holder lid slowly in the direction indicated by the arrow.

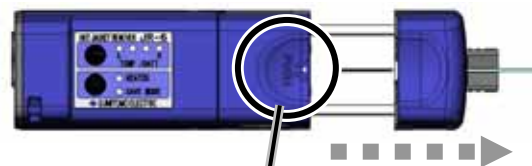

Tips

Hold the "PUSH" portion firmly.

Slide the holder receptacle and holder lid slowly.

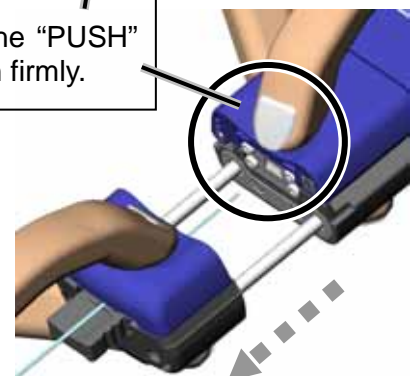

6. Coating removal is complete. Take out the fiber holder from the JR-6. Also take out the removed fiber coating with a supplied cleaning brush.

Removed fiber coating

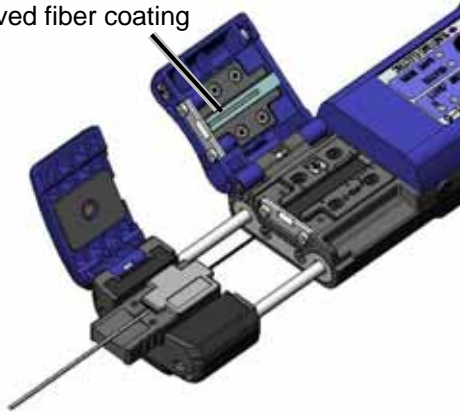

 Caution	Be sure to take out removed fiber coating and dispose of it.
-------------	--



7. Press the POWER key for more than 1 second until the indicator LEDs go off.

8. Clean the bare fiber from the end of the fiber coating with a lint-free gauze pad moistened with pure (more than 99%) alcohol. Pull the bare fiber in the direction indicated by the arrow through the gauze pad (if cleaning ribbon fiber). Do not reuse the gauze pad that was used.

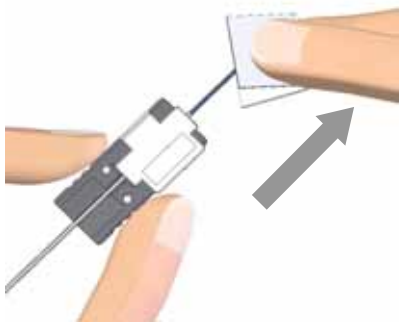

9. Lightly brush the ends with your finger to fan out all fibers in a straight line (if cleaning ribbon fiber).

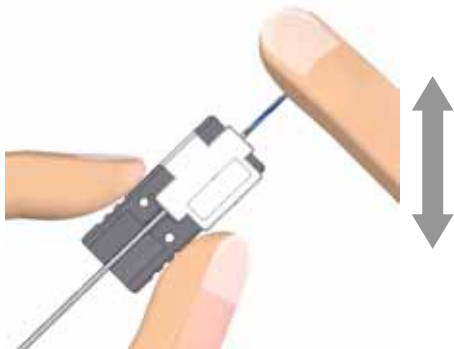

 Caution	Glass fiber is extremely sharp. Handle with care.
-------------	---

6. Temperature setting

The set temperature can be changed by using the TEMP. key (2). The factory default is the second position from the left.

Normally you can use the factory default.

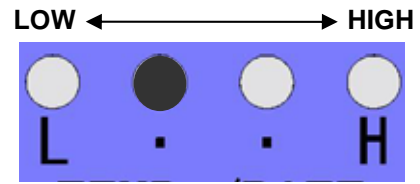

Some problems, for example fiber coating is hard to remove, fiber coating is crumbled, and etc. may occur depending on the optical fibers being used or operating conditions. In this case, change the set temperature.

*Changing the set temperature may shorten battery operating duration.

7. HEATER MODE switching

While the JR-6 is powered on, you can switch between NORMAL MODE and POWER SAVE MODE by pressing the POWER key (1) for a short period of time (less than 1 second). Generally NORMAL MODE is recommended.

*If the POWER key is pressed for more than 1 second, the JR-6 is powered off.

1. NORMAL MODE

NORMAL MODE enables to use the JR-6 continuously with no waiting time.

2. POWER SAVE MODE

POWER SAVE MODE enables to minimize power consumption and extend battery operating duration. If the main body lid is not opened or closed for approx. 20 seconds after the HEATER LED turns green from red, the JR-6 decreases temperature and keeps low temperature. (The HEATER LED is lit in red.) If the main body lid is opened or closed, the JR-6 starts to increase temperature.

8. Auto power off function

If the main body lid is not opened or closed for 15 minutes, the JR-6 is powered off automatically.

9. Maintenance

Cleaning

To keep the JR-6 in good condition, be sure to clean it before and after use.

Before cleaning the JR-6, make sure that the JR-6 is in the following conditions.

1. The JR-6 is powered off.
2. The BU-6 battery is removed from the JR-6.
3. The heat plate is cooled down. (Wait for more than 5 minutes after the JR-6 is powered off.)

Clean the blades, heat plate and rubber pad with a cotton swab moistened with pure alcohol.

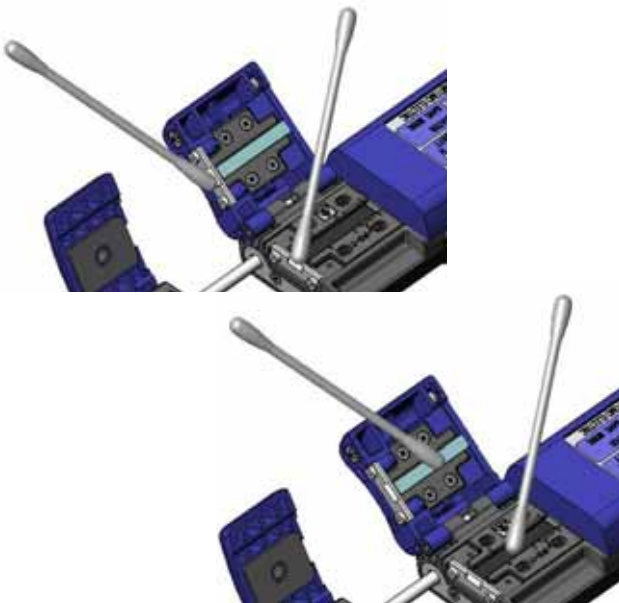

Caution

1. Dust such as coating residue on the blades, heat plate and rubber pad may cause removing performance to be deteriorated.
2. Do not use chemicals other than pure alcohol. Alcohol with low purity will rust the blades and deteriorate the rubber pad easily.

Blade replacement

Blades are very sharp. Handle with care.

Before replacing the blades, make sure that the JR-6 is in the following conditions.

1. The JR-6 is powered off.
2. The BU-6 battery is removed from the JR-6.
3. The heat plate is cooled down. (Wait for more than 5 minutes after the JR-6 is powered off.)



Caution

Always replace the upper and lower blades at a time.
Upper and lower blades are the same.

1. Loosen the setscrews with a supplied Hex driver (US) or Allen key (UK). Remove the upper and lower blades.



2. Fit a new lower blade to the JR-6 and tighten the setscrews temporarily.

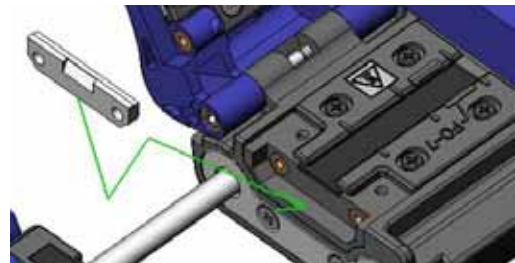

3. Fit a new upper blade to the JR-6 and tighten the setscrews temporarily.

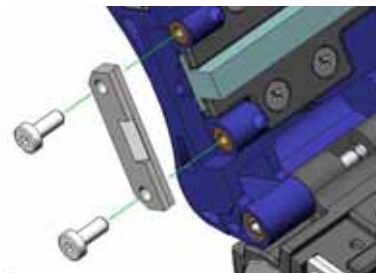

4. Loosen the setscrews of the upper and lower blades so that the blades are a little movable back and forth.



Ensure that the upper and lower blades are movable.

5. Adjust the positions of the blades.

Close the main body lid. Put a Hex driver (US) or Allen key (UK) in the hole of the "PUSH" portion. While pressing the Hex driver (US) or Allen key (UK) to the upper blade in the direction indicated by the arrow, tighten the setscrews so that the upper blade is aligned with the lower blade.

Tips Tighten the left and right setscrews alternately with even tightening force.
[Reference] Optimum torque: 17.6cNm

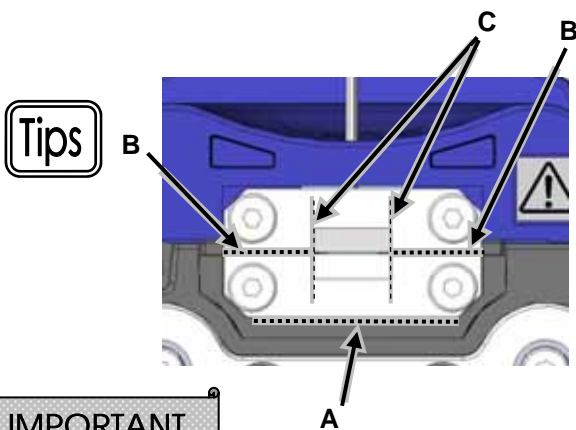
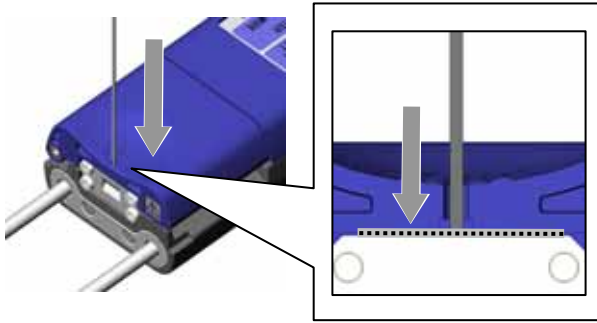

IMPORTANT

- A:** There should not be a gap between the lower blade and JR-6 main body.
- B:** There should not be a gap between the upper and lower blades.
- C:** The upper and lower blades should be aligned with each other.

6. Attempt to remove coating of ribbon fiber a few times. Lightly brush the ends with your finger and ensure that the fiber is not broken.

10. Troubleshooting



Good



No good



Fiber is broken.



Fiber coating is not removed nicely.



Fiber coating cannot be removed.

If a removing problem occurs, the followings are possible causes.

(A) Cleaning is not conducted fully.

Dust such as coating residue on the blades, heat plate and rubber pad may cause removing performance to be deteriorated. Clean the JR-6 referring to "9. Maintenance-Cleaning".

(B) The blades do not touch the fiber coating.

-1. The blades are not fitted to the JR-6 properly. Check to see if the blades are fitted to the JR-6 properly referring to "9. Maintenance-Blade replacement".

-2. The blades are worn out.

If a removing problem still persists despite correct blade fitting, the blades may be worn out. Contact our maintenance service center.

-3. The "PUSH" portion of the main body lid is not pressed fully.

Hold the "PUSH" portion firmly when removing fiber coating.

(C) Fiber coating is hard to remove. Fiber coating is crumbled.

Depending on the fiber coating materials or ambient temperature, a set temperature needs to be changed. Generally increase the temperature at low ambient temperature.

11. Single fiber adapter (option)

Fitting the single fiber adapter

As shown below, fit the SFA-6 single fiber adapter to the JR-6 with supplied screws.

[Reference] Optimum torque: 17.6cNm

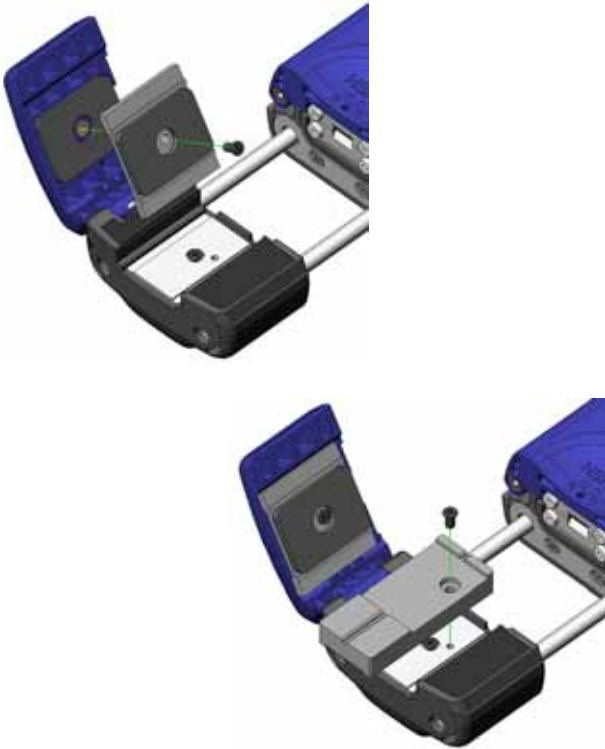

Using the single fiber adapter

1. Load a single fiber in the SFA-6 single fiber adapter with the end protruding max. 30mm.



2. Close the main body lid and holder lid. After a few seconds the HETER LED lights up green.

3. Hold the "PUSH" portion of the main body lid firmly. Then slide the holder receptacle and holder lid slowly in the direction indicated by the arrow.

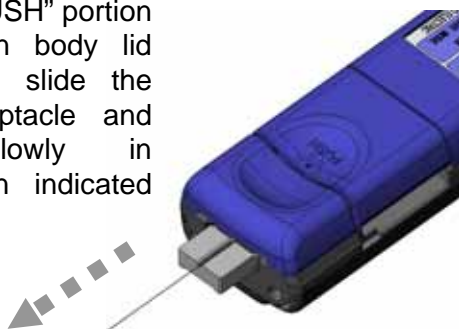

4. Coating removal is complete. Take out the fiber from the JR-6. Also take out the removed fiber coating with a supplied cleaning brush.

12. Battery storage

If you are going to store the battery for more than 1 month, observe the followings.

1. Remove the battery from the JR-6.
(Refer to "4. Preparing power supply-Battery replacement".)
2. Store the battery in a cool temperature e.g. approx. 20 °C.
3. Charge the battery for approx. 20 minutes once a year.
(Refer to "4. Preparing power supply-Charging the battery".)

Tokyo (JAPAN)
Sumitomo Electric Industries, Ltd.
(Global Business Dept.)
3-9-1, Shibaura, Minato-ku, Tokyo 108-8539 JAPAN
Tel: +81 (0)3 6722 3246
<http://www.sei.co.jp>

North Carolina (U.S.A)
Sumitomo Electric Lightwave Corp.
78 Alexander Drive, P.O. Box 13445, Research Triangle park,
NC27709 U.S.A
Tel: +1 919 541 8100
<http://www.sumitomoelectric.com>

London (U.K)
Sumitomo Electric Europe Ltd.
220 Centennial Park, Centennial Avenue, Elstree, Herts, WD6 3SL, U.K.
Tel: +44 (0)20 8953 8118
<http://www.sumielectric.com>

Hong Kong
Sumitomo Electric Asia, Ltd.
Tel: +852 2576 0080

Beijing (China)
SUMIDEN ASIA (SHENZHEN) Co., Ltd.
(Beijing Branch)
Tel: +86 10 6590 8196

Shanghai (China)
SUMIDEN ASIA (SHENZHEN) Co., Ltd.
(Shanghai Branch)
Tel: +86 21 6235 1036

Guangzhou (China)
SUMIDEN ASIA (SHENZHEN) Co., Ltd.
(Guangzhou Branch)
Tel: +86 20 3877 2808

Bangkok (Thailand)
Sumitomo Electric (Thailand) Limited
Tel: +66 (0)2 260 7231 to 5

Singapore
Sumitomo Electric Interconnect Products
(Singapore) Pte Ltd.
Tel: +65 6261 3388

New Delhi (India)
Sumitomo Electric Industries, Ltd.
New Delhi Liason Office
Tel: +91 120 434 7701/7702

Philippines
Sumitomo Electric Industries
(Philippines) Incorporated
Tel: +63 2 811 2755/2756